Allegro Package Designations

This document provides reference information as an aid to differentiating the device package types used by Allegro[®] MicroSystems. It provides cross references to the *package designation*, an Allegro code that is integrated into the device part number:

- alphabetical listing of Allegro package designators, with differentiating specifications and reference illustrations
- alphabetical listing of common or obsolete package designators, cross-referenced to Allegro designators
- key to interpreting Allegro part numbers for package designators
- key to interpreting Allegro terms for lead forms

The package designator is used to differentiate the external physical characteristics of the packages for ordering purposes.

To use this document, in the Allegro Package Code column, locate the package designator for the device. Alternatively, use the drawings to identify a package, or the cross-reference to common terms.

A few package types have leadform options. These options are indicated by the *instruction* codes, shown in parentheses in the Package Designation column. Leadform options are shown in separate rows. Leadform options are not always available for every device type.

The options available for any specific device are substantially determined by the package designa-

tion for that device. Not all options are available for any particular package designation or device type, and provision of certain configurations may be subject to minimum volume or NCNR (noncancellation, nonreturn) limitations.

For clarity and differentiation, the drawings are schematic and not to scale, however, a representative footprint is provided at approximately actual size of the package body when mounted on a PCB. The drawings do not represent all possible configurations of that device, or any particular device, and may have features that vary according to supplier preference within specifications, such as pin 1 index marks. Exposed thermal pads may have several alternative layouts for any particular package designation.

When applicable, references to industry-standard type conventions, such as JEDEC package registrations, are provided. These references are for informational purposes only, and do not necessarily indicate that the device indicated conforms fully with those standards in all respects.

NOTE: For information on packages and leadform configurations offered for individual devices, refer to the datasheet for the device.

Allegro MicroSystems, Inc. reserves the right to make, from time to time, such departures from the detailed specifications as may be required to permit improvements in the design of its products. The information included herein is believed to be accurate and reliable. However, Allegro MicroSystems, Inc. assumes no responsibility for its use; nor for any infringements of patents or other rights of third parties which may result from its use.

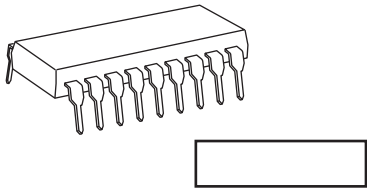
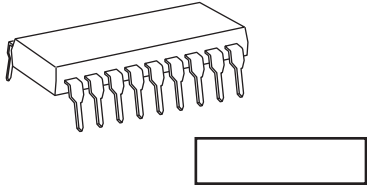
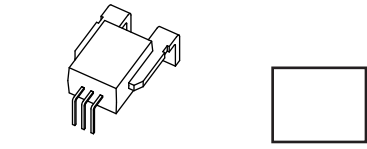
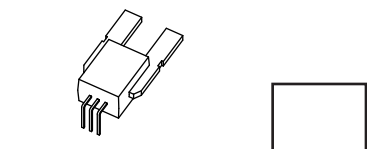
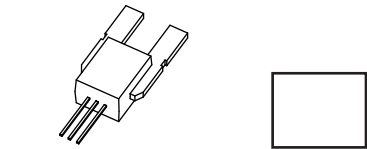
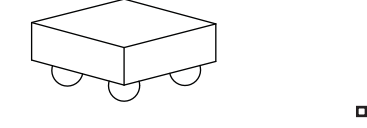
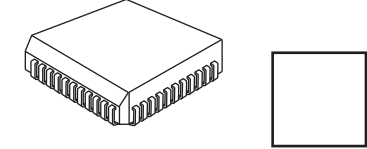
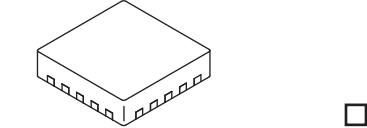
Package Designator	Package Type (Common Package Designator)	JEDEC Package Outline	Quantity of Terminals	Pictorial View/ Representative Footprint
A	Plastic dual in-line (DIP/PDIP/DIL/PDIL) Through hole pin, 300 mil row spacing "BB" half-lead end pins	MS-001AA MS-001BB MS-001AC MS-001AD MS-001AF	14 16 18 20 24	
	Plastic dual in-line (DIP/PDIP/DIL/PDIL) Through hole pin, 400 mil row spacing	MS-010AA	22	
	Plastic dual in-line (DIP/PDIP/DIL/PDIL) Through hole pin, 600 mil row spacing	MS-011AB	28	
B	Semi-tab plastic dual in-line (DIP/PDIP/DIL/PDIL) with internally fused leads, both sides; Through hole pin, 300 mil row spacing "BB" half-lead end pins	MS-001BB MS-001AF	16 24	
CA/CB (PFF)	Plastic case with internally fused primary conductor leads for sensed current Through hole pin	-	5	
CA/CB (PSF)	Plastic case with internally fused primary conductor leads for sensed current Through hole/weld pin	-	5	
CA/CB (PSS)	Plastic case with internally fused primary conductor leads for sensed current Through hole/weld pin	-	5	
CG	Bare die with solder bumps (WLCSP)	-	Various	
CW	Wafer with bare die	-	Various	-
EA	Plastic leaded chip carrier (PLCC/PQCC); square body; internally fused leads, one side Socket J lead	MS-018AB	28	
EB	Plastic leaded chip carrier (PLCC/PQCC); square body; internally fused leads, two opposite sides Socket J lead	MS-018AB MS-018AC	28 44	
EC	Plastic leadless package with quad (4) populated sides and exposed thermal pad (MLPQ/QFN); square body, 0.75 mm nominal (0.80 maximum) height Surface mount contacts, 0.40 mm contact pitch	MO-220WGGE	26, 28	





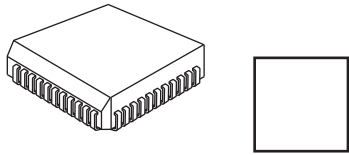
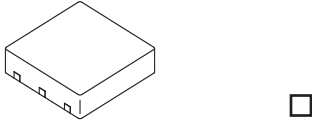
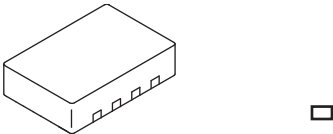
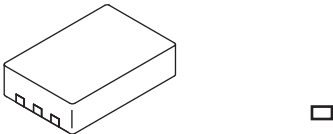
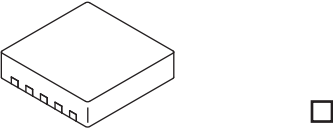
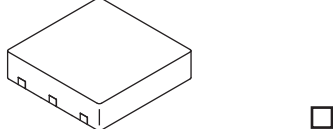
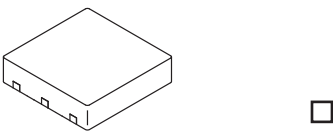
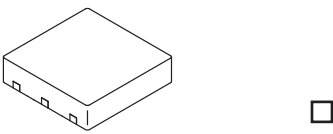
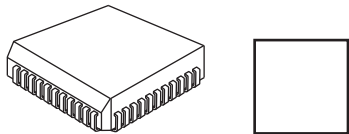
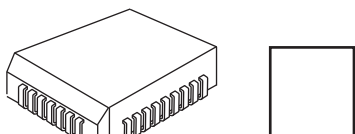





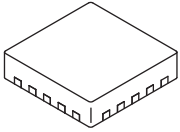

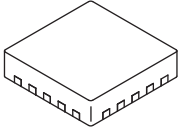

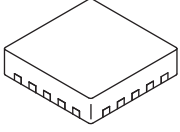
Continued on next page...

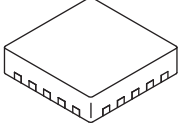
Continued from previous page...

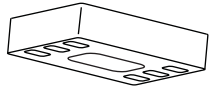
Package Designator	Package Type (Common Package Designator)	JEDEC Package Outline	Quantity of Terminals	Pictorial View/ Representative Footprint
ED	Plastic leaded chip carrier (PLCC/PQCC); square body; internally fused leads, four sides Socket J lead	MS-018AC	44	
EE	Plastic leadless package with dual (2 opposite) populated sides and exposed thermal pad (MLPD/DFN/SON); square body, variable footprint; 0.60 mm maximum height (ultra thin profile) Surface mount contacts, 0.50 mm contact pitch	MO-229UCCD	8	
EF	Plastic leadless package with dual (2 opposite) populated sides (longer sides) and exposed thermal pad (MLPD/DFN/SON); rectangular body, 6 x 5 mm (pin-compatible with SOICN-8, see package L), 0.90 mm nominal height Surface mount contacts, 1.27 mm contact pitch	MO-229VLJD Type2	8	
EH	Plastic leadless package with dual (2 opposite) populated sides (shorter sides) and exposed thermal pad (MLPD/DFN/SON); rectangular body, 2 x 3 mm, 0.75 mm nominal (0.80 maximum) height Surface mount contacts, 0.50 mm contact pitch	MO-229WCED Type1	6	
EJ	Plastic leadless package with dual (2 opposite) populated sides and exposed thermal pad (MLPD/DFN/SON); square body, variable footprint; 0.75 mm nominal (0.80 maximum) height Surface mount contacts, 0.50 mm contact pitch	MO-229WEED	10	
EK	Plastic leadless package with dual (2 opposite) populated sides and exposed thermal pad (MLPD/DFN/SON); square body, variable footprint; 0.75 mm nominal (0.80 maximum) height Surface mount contacts, 0.95 mm contact pitch	MO-229WEEA	5, 6	
EL	Plastic leadless package with dual (2 opposite) populated sides and exposed thermal pad (MLPD/DFN/SON); square body, variable footprint, 0.55 mm maximum height (ultra thin profile) Surface mount contacts, 0.50 mm contact pitch	MO-229UCCD	3, 6	
EM	Plastic leadless package with dual (2 opposite) populated sides and exposed thermal pad (MLPD/DFN/SON); square body, variable footprint, 0.45 mm nominal (0.50 mm maximum) height Surface mount contacts, 0.65 mm contact pitch	MO-229XCCC	5	
EP	Plastic leaded chip carrier (PLCC/PQCC); square body Socket J lead	MS-018AA MS-018AB MS-018AC	20 28 44	
EQ	Plastic leaded chip carrier (PLCC/PQCC); rectangular body Socket J lead	MS-016AE	32	

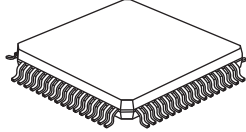
Continued on next page...

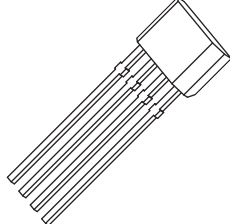
Continued from previous page...

Package Designator	Package Type (Common Package Designator)	JEDEC Package Outline	Quantity of Terminals	Pictorial View/ Representative Footprint
ES	Plastic leadless package with quad (4) populated sides and exposed thermal pad (MLPQ/QFN); square body, 0.75 mm nominal (0.80 maximum) height Surface mount contacts, 0.50 mm contact pitch	MO-220WEED MO-220WGGD	16 20, 24	 
ET	Plastic leadless package with quad (4) populated sides and exposed thermal pad (MLPQ/QFN); square body, 5 x 5 mm maximum footprint; 0.90 mm nominal height (1.00 maximum) Surface mount contacts, 0.50 mm contact pitch	MO-220VHHD	28, 32	 
EU	Plastic leadless package with quad (4) populated sides and exposed thermal pad (MLPQ/QFN); square body, 0.75 mm nominal (0.80 mm maximum) height Surface mount contacts, 0.65 mm contact pitch	MO-220WGGC	16	 
EV	Plastic leadless package with quad (4) populated sides and exposed thermal pad (MLPQ/QFN); square body, 6 x 6 mm minimum footprint; 0.90 mm nominal (1.00 maximum) height Surface mount contacts, 0.50 mm contact pitch	MO-220VJJD MO-220VKKD	36, 40 48	 
EW	Plastic leadless package with dual (2) populated sides and exposed thermal pad (MLPD/DFN/SON); rectangular body, 0.40 mm maximum height (super-thin profile) Surface mount contacts, variable footprint (including pullback contacts), 0.50 mm contact pitch	MO-229X2BCD Type1	6	 
JP	Plastic low-profile quad flatpack with exposed thermal pad (LQFP, eLQFP) 1.4 mm nominal body thickness Gull wing surface mount	MS-026BBCHD	48	 
JS	Plastic thin-profile quad flatpack with exposed thermal pad (TQFP, eTQFP) 1.0 mm nominal body thickness Gull wing surface mount, 0.50 mm contact pitch	MS-026ADDHD	80	
JU	Plastic thin-profile quad flatpack (TQFP) 1.0 mm nominal body thickness Gull wing surface mount, 0.50 mm contact pitch	MS-026ABC	48	
K (none)	Plastic single in-line (SIP) Through hole pin	-	4	 

Continued on next page...

Continued from previous page...

Package Designator	Package Type (Common Package Designator)	JEDEC Package Outline	Quantity of Terminals	Pictorial View/ Representative Footprint
K (TL,TS)	Plastic single in-line (SIP) Pins formed for horizontal body mounting	–	4	Pictorial view of a plastic single in-line package with four pins. The footprint is a small rectangle.
KA (none)	Plastic single in-line (SIP) Through hole pin	–	5	Pictorial view of a plastic single in-line package with five through-hole pins. The footprint is a small rectangle.
KA (TL,TS)	Plastic single in-line (SIP) Pins formed for horizontal body mounting	–	5	Pictorial view of a plastic single in-line package with five pins. The footprint is a small rectangle.
KB	Plastic single in-line (SIP) Through hole pin	–	3	Pictorial view of a plastic single in-line package with three through-hole pins. The footprint is a small rectangle.
KT	Plastic single in-line (SIP) Through hole pin	–	4	Pictorial view of a plastic single in-line package with four through-hole pins. The footprint is a small rectangle.
L	Plastic small-outline IC (SOIC, SO, SOP); 3.90 mm/150 mil body width Gull wing surface mount, 1.27 mm lead pitch	MS-012AA MS-012AB MS-012AC	8 14 16	Pictorial view of a plastic small-outline IC package with gull-wing leads. The footprint is a rectangle.
LA	Plastic small-outline IC (SOIC-W, SOP) with internally fused primary conductor leads for sensed current; 7.50 mm/300 mil body width Gull wing surface mount, 1.27 mm lead pitch	MS-013AA	16	Pictorial view of a plastic small-outline IC package with gull-wing leads. The footprint is a rectangle.
LB	Plastic small-outline IC (SOIC-W, SOP) with internally fused leads, both sides; 7.50 mm/300 mil body width Gull wing surface mount, 1.27 mm lead pitch	MS-013AA MS-013AC MS-013AD MS-013AE	16 20 24 28	Pictorial view of a plastic small-outline IC package with gull-wing leads on both sides. The footprint is a rectangle.



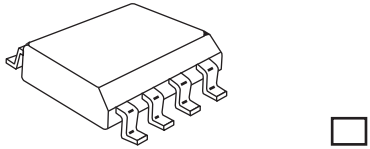
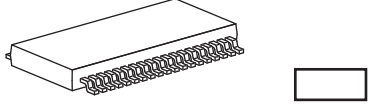
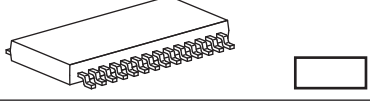
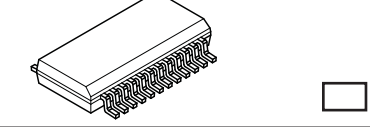
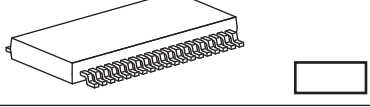
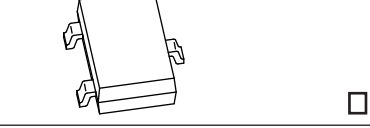
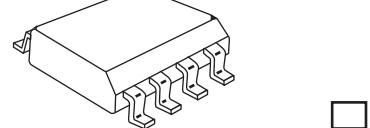
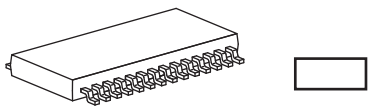
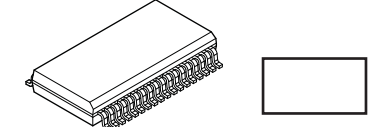
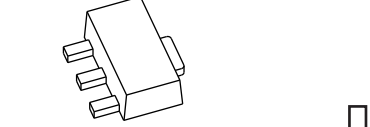
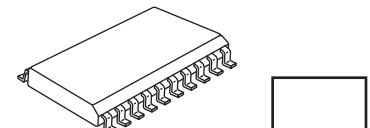

Continued on next page...

Continued from previous page...

Package Designator	Package Type (Common Package Designator)	JEDEC Package Outline	Quantity of Terminals	Pictorial View/ Representative Footprint
LC	Plastic small-outline IC (SOIC, SO, SOP) with internally fused primary conductor leads for sensed current; 3.90 mm/150 mil body width Gull wing surface mount, 1.27 mm lead pitch	MS-012AA	8	
LD	Plastic thin shrink small-outline IC (TSSOP); 4.4 mm body width Gull wing surface mount, 0.50 mm lead pitch	MO-153BD-1	38	
LE	Plastic thin shrink small-outline IC (TSSOP); 4.4 mm body width Gull wing surface mount, 0.65 mm lead pitch	MO-153AC	20	
LF	Plastic small-outline IC (QSOP, appearance like SOIC) sensor variant with internally fused primary conductor leads for sensed current; 3.90 mm body width Gull wing surface mount, 0.635 mm lead pitch	MO-137AE	24	
LG	Plastic thin shrink small-outline IC (TSSOP); with internally fused leads, both sides; 4.4 mm body width Gull wing surface mount, 0.50 mm lead pitch	MO-153BD-1	38	
LH	Plastic small-outline transistor (SOT23W-3, SOHED); 1.98 mm body width Mini gull wing surface mount	-	3	
LJ	Plastic small-outline IC (SOIC, SO, SOP) with exposed thermal pad; 3.90 mm/150 mil body width Gull wing surface mount, 1.27 mm lead pitch	MS-012BA	8	
LP	Plastic thin shrink small-outline IC with exposed thermal pad (HTSSOP); Gull wing surface mount, 0.65 mm lead pitch 4.4 mm body width	MO-153ABT MO-153ACT MO-153ADT MO-153AET	16 20 24 28	
LQ	Plastic small-outline IC (QSOP, appearance like SOIC) 7.50 mm/300mil body width Gull wing surface mount, 0.80 mm lead pitch	-	36	
LT	Plastic small-outline transistor, thermally enhanced with exposed ground tab (SOT89, SC-62) Surface mount flat lug lead	TO-243AA	3	
LW	Plastic small-outline IC (SOIC-W, SOP); 7.50 mm/300 mil body width Gull wing surface mount, 1.27 mm lead pitch	MS-013AA MS-013AB MS-013AC MS-013AD MS-013AE	16 18 20 24 28	

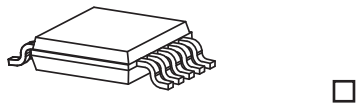
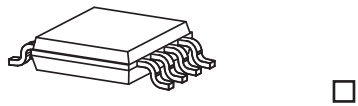
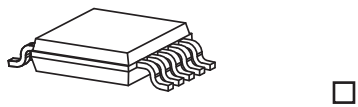
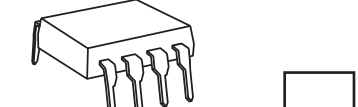
Continued on next page...

Continued from previous page...

Package Designator	Package Type (Common Package Designator)	JEDEC Package Outline	Quantity of Terminals	Pictorial View/ Representative Footprint
LY	Mini small outline (MSOP, SOP: appearance like TSSOP); with exposed thermal pad Gull wing surface mount, 0.50 mm lead pitch	MO-187BA-T	10	
LZ	Mini small outline (MSOP, SOP: appearance like TSSOP); Gull wing surface mount, 0.65 mm lead pitch	MO-187AA	8	
	Mini small outline (MSOP, SOP: appearance like TSSOP); Gull wing surface mount, 0.50 mm lead pitch	MO-187BA	10	
M	Mini plastic dual in-line (DIP/PDIP); 300 mil row spacing, half-lead end pins Through hole pin	MS-001BA	8	
SA	Plastic case (SIP); 9 mm body height Through hole pin	-	4	
SB	Plastic case (SIP); 7 mm body height Through hole pin	-	4	
SE	Plastic single in-line (SIP), round top; Spread pins Through hole pin Molded lead bar	-	4	



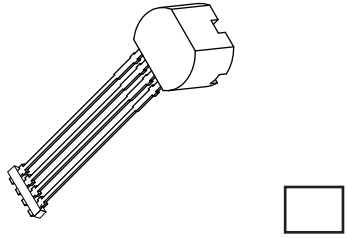
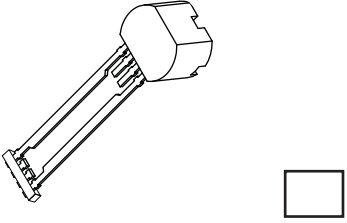
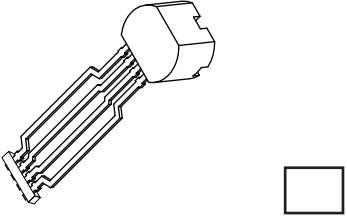
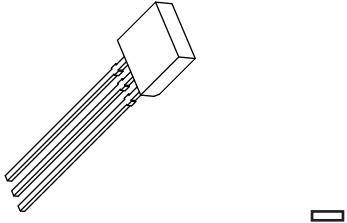
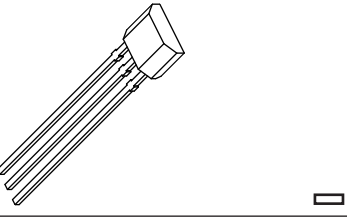
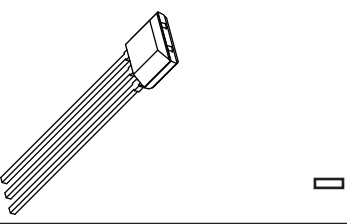

Continued on next page...

Continued from previous page...

Package Designator	Package Type (Common Package Designator)	JEDEC Package Outline	Quantity of Terminals	Pictorial View/ Representative Footprint
SG	Plastic single in-line (SIP), flat top; Straight full pins Through hole pin Molded lead bar	–	4	
SH	Plastic single in-line (SIP), flat top; Pins 2 and 3 clipped, pins 1 and 4 wide Through hole pin Molded lead bar	–	4	
SJ	Plastic single in-line (SIP), flat top; Spread pins Through hole pin Molded lead bar	–	4	
U	Plastic mini single in-line (SIP); Through hole pin	–	3	
UA (TI, TN, TJ)	Conventional. Plastic ultramini single in-line (SIP) Through hole pin, 1.27 mm pin pitch, 15.75 mm leads	–	3	
	Matrix. Plastic ultramini single in-line (SIP) Through hole pin, 1.27 mm pin pitch, 14.99 mm leads	–	3	

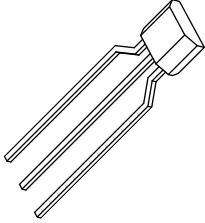
Continued on next page...

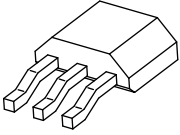
Continued from previous page...

Package Designator	Package Type (Common Package Designator)	JEDEC Package Outline	Quantity of Terminals	Pictorial View/ Representative Footprint
UA (LC,TA)	Plastic ultra-mini single in-line (SIP) Through hole pin, 2.54 mm pin pitch, conventional or matrix	-	3	 
UA (TL,TS)	Plastic ultra-mini single in-line (SIP) Pins formed for horizontal body mounting 50 mil pin pitch, conventional or matrix	-	3	 

Common Package Term Cross-reference

Common Configuration Terms

Term	Package Designator
CSP	CG
DFN	EE EF EH EJ EK EL EM EW
DIP	A B M
LQFP	JP
MSOP	LY, LZ
PLCC	EA EB ED EP EQ
QFN	ES ET EU EV
QSOP	LF LQ

Term	Package Designator
SIP	K KA KB KT SA SB SC SE SG SH SJ U UA
SOIC-N	L LC LJ
SOIC-W	LA LB LW
SOT23	LR
SOT23-W	LH
SOT89	LT
TQFP	JS JU
TSSOP	LD LE LG LP
Wafer (undiced)	CW
WLCSP	CG

Common Package Term Cross-reference (continued)

Alternative Terms for Configurations (other industry terms or obsolete)

Term	Package Designator
Bumped Die	CG
DIL	See DIP
eTSSOP	See LP
Flip Chip	CG
GTS2000	SE SG SH SJ
HED	K KA KB KC KT U UA
HTSSOP	See LP

Term	Package Designator
MLP	See DFN and QFN
MLPD	See DFN
MLPQ	See QFN
PDIL	See DIP
PDIP	See DIP
PQCC	See PLCC
PQFN	See QFN
PSON	See DFN
SC-62	LT
SO	L LC LJ
SOHED	LH

Term	Package Designator
SOIC appearance	See QSOP
SOP	L LA LB LC LJ LW LZ
SON	See DFN
TDFN	See DFN
TSSOP appearance	See MSOP

QFN/DFN/SON/MLP Dimensional Cross-Reference

Sort by Contact Pitch			
	Pitch (mm)	Maximum Height (mm)	Size Constraint
EC	0.40	0.80	
EE	0.50	0.60	
EH	0.50	0.80	Type 1
EJ	0.50	0.80	
EL	0.50	0.55	
ES	0.50	0.80	
ET	0.50	1.00	5 mm x 5 mm max
EV	0.50	1.00	6 mm x 6 mm min
EW	0.50	0.40	Type 1
EM	0.65	0.50	
EU	0.65	0.80	
EK	0.95	0.80	
EF	1.27	1.00	Type 2

Sort by Overall Package Height			
	Maximum Height (mm)	Pitch (mm)	Size Constraint
EW	0.40	0.50	Type 1
EM	0.50	0.65	
EL	0.55	0.50	
EE	0.60	0.50	
EC	0.80	0.40	
EH	0.80	0.50	Type 1
EJ	0.80	0.50	
EK	0.80	0.95	
ES	0.80	0.50	
EU	0.80	0.65	
EF	1.00	1.27	Type 2
ET	1.00	0.50	5 mm x 5 mm max
EV	1.00	0.50	6 mm x 6 mm min

Complete Part Number Format ("A" initial character style, general product lines)

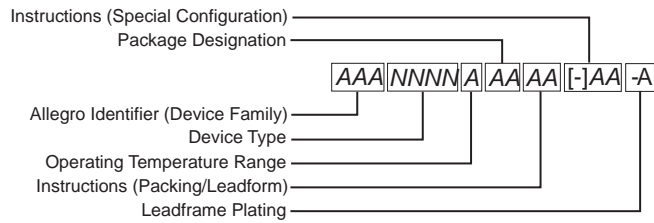

Allegro Identifier	[A, and optional 1 to 2 letters]
Device Type	[3 to 4 numbers] functional type
Operating Temperature Range	[1 letter] ambient temperature range
Package Designation	[1 or 2 letters] body configuration
Instructions	Leadform/packing option, etc. Blank indicates default configuration
Leadframe Plating	["-" and 1 letter] nonlead (Pb-free) option

Complete Part Number Format ("U" initial character style, general product lines)

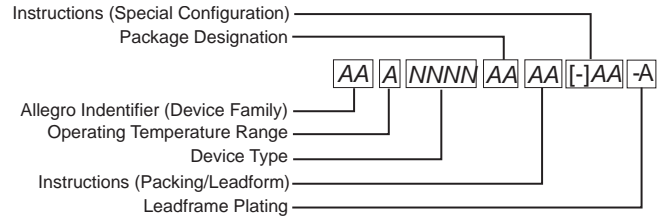

Allegro Identifier	[U, and optional 1 letter]
Operating Temperature Range	[1 letter] ambient temperature range
Device Type	[3 to 4 numbers] functional type
Package Designation	[1 or 2 letters] body configuration
Instructions	Leadform/packing option, etc. Blank indicates default configuration
Leadframe Plating	["-" and 1 letter] nonlead (Pb-free) option

Complete Part Number Format (Sensed current range style, current sensor IC product lines)

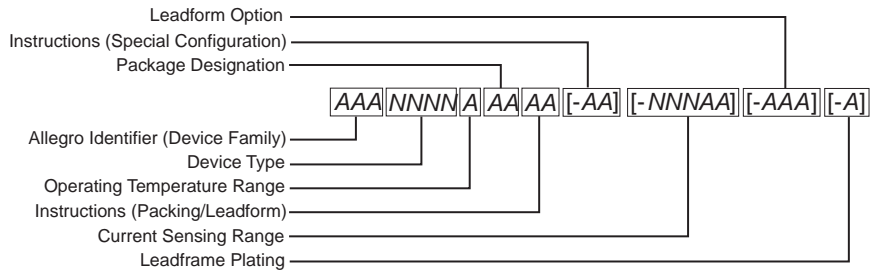

Allegro Identifier	ACS
Device Type	[3 to 4 numbers] functional type
Operating Temperature Range	[1 letter] ambient temperature range
Package Designation	[1 or 2 letters] body configuration
Instructions	Leadform/packing option, etc. Blank indicates default configuration
Current Sensing Range	[3 numbers] optimal sensing amperage range
	[1 letter] measurable sensing range multiplier. A: 1×optimal, B: 2×optimal, C: 3×optimal
	[1 letter] current direction measurable. B: bidirectional, U: unidirectional
Leadform (75x series)	[3 letters] PFF: formed signal leads, formed current terminals, PSF: formed signal leads, straight current terminals, PSS: straight signal leads, straight current terminals
Leadframe Plating	["-" and 1 letter] nonlead (Pb-free) option

Terms Used to Describe Lead Configurations

Term	Description	Example
X Direction Separation		
Straight	Straight over full length, and perpendicular to package surface	K
Spread	Straight at package surface, with increased pitch after bend	SJ
Fused leads	Internally fused leads for increased thermal conductance (formerly: <i>semi-tab</i>)	LB
Joined	Straight at package surface, with merge after bend	KB
Y Direction Length		
Untrimmed	All leads at longer length	UA (TI ordering Instruction)
Trimmed	All leads at shorter length	UA (TL ordering Instruction)
Clipped	Some leads shorter than other leads	SH
Z Direction Forming		
Unformed	Straight and perpendicular to package surface	UA (TI ordering Instruction)
Formed	Straight at package surface, then bent toward mounting surface	UA (TL ordering Instruction)

